

MOUNTING FLANGE (SAE J744)

-SB2

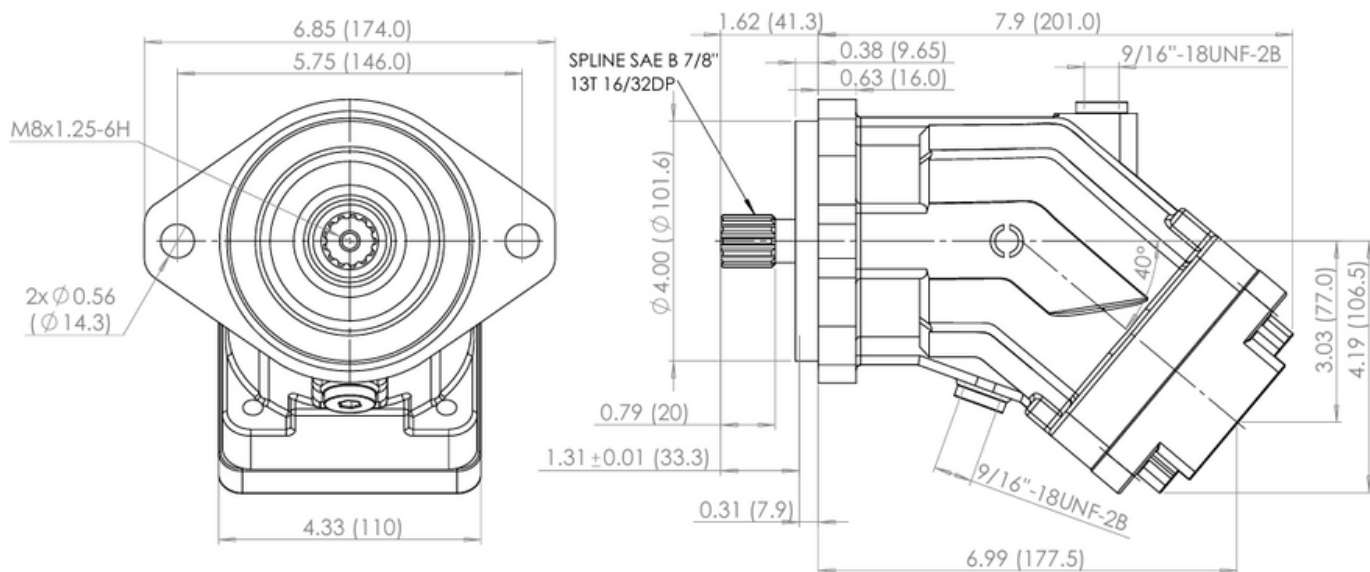

-SB4

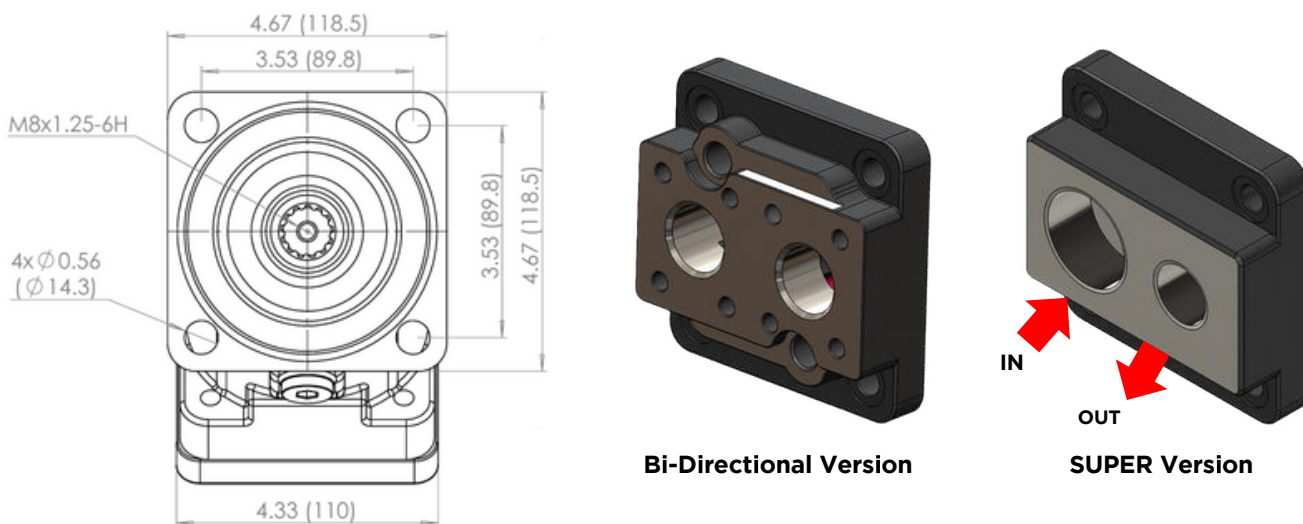

Bi-Directional Version

SUPER Version

-Shaft

Spline Shaft



Keyed Shaft

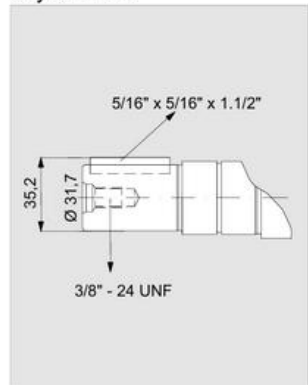

Keyed Shaft

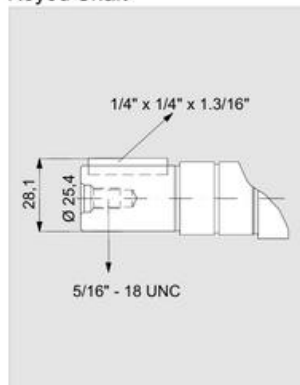

Keyed Shaft

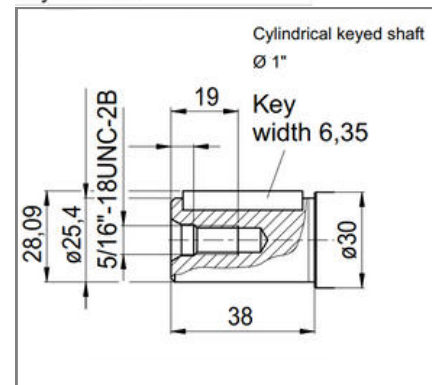

x 1000 rpm	32,00 cc
x 1500 rpm	48,00 cc
Max. Continuous Pump Speed	2250 rpm
Max. Limited Pump Speed	2700 rpm
Max. Continuous Pressure	350 bar
Max. Intermit. Peak Pressure	400 bar
Max. Torque at 350 bar	190 Nm
Weight without inlet fitting	10,50 kg
Weight with inlet fitting	10,90 kg
Torque without inlet fitting	11,00 N.m
Torque with inlet fitting	11,52 N.m
Rotation	CW-CCW
Fluid	Min.B.Hyd.Oil
Inlet & Outlet	1"

32

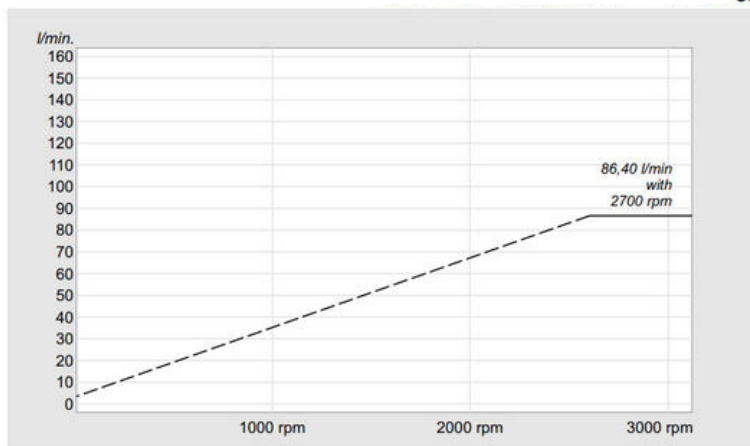

x 1000 rpm	40,20 cc
x 1500 rpm	60,30 cc
Max. Continuous Pump Speed	1900 rpm
Max. Limited Pump Speed	2500 rpm
Max. Continuous Pressure	350 bar
Max. Intermit. Peak Pressure	400 bar
Max. Torque at 350 bar	240 Nm
Weight without inlet fitting	10,50 kg
Weight with inlet fitting	10,90 kg
Torque without inlet fitting	11,12 N.m
Torque with inlet fitting	11,40 N.m
Rotation	CW-CCW
Fluid	Min.B.Hyd.Oil
Inlet & Outlet	1"

40

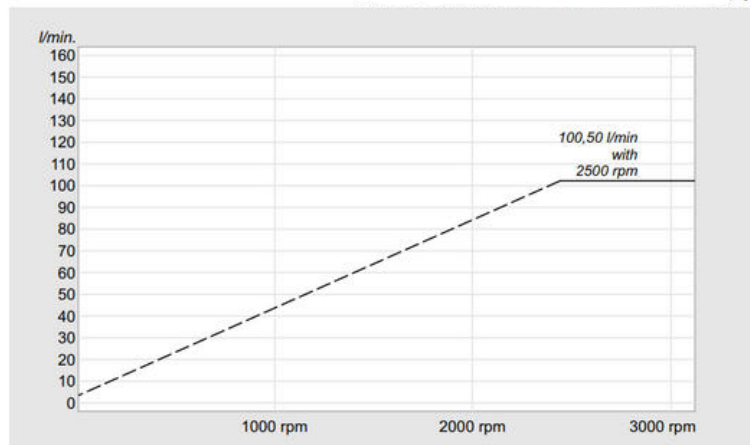

Charts are for Bi-directional. Super version has better high speed performance and suction character.



C-2PE: Ordering Code and Specifications Table

Type Code	Displacement (cm3)	Rotation	Version	Sealing	Mounting Flange	Shaft	Flow	Inlet Fitting
C-2PE	12,18,25,32, 40,50,63,80, 108,130	Right, Left (cw,ccw)	Special Classic (S,C)	Nitrile, Viton (N,V)	According the Specifications	According the Specifications	S, B (Super, Bidirectional)	A (Inculet with Bidirectional and cover)

	12	18	25	32	40	50	63	80	108	130	
SB2	●	●	●	●	●						SAE B-2 Hole
SB4	●	●	●	●	●	●	●				SAE B-4 Hole
SC4						●	●	●	●	●	SAE C-4 Hole

	12	18	25	32	40	50	63	80	108	130	
B13	●	●	●	●	●	●	●				SAE B 13T 16/32
BB15				●	●	●	●				SAE BB 15T 16/32
C14						●	●	●	●	●	SAE C 14T 12/24
D13								●	●	●	SAE D 13T 8/16
K1	●	●	●	●	●	●	●				1" Parallel Keyed
K1114				●	●	●	●	●	●	●	1 1/4" Parallel Keyed

ISO1179, SAE J1926, ISO6149

*Availabe on Request

Bidirectional Rear			
IN	OUT		
12	G3/4, SAE 12	G3/4, SAE 12	
18	G3/4, SAE 12	G3/4, SAE 12	
25	G3/4, SAE 12	G3/4, SAE 12	
32	G1, SAE 16	G1, SAE 16	
40	G1, SAE 16	G1, SAE 16	
50	G1, SAE 16	G1, SAE 16	B02
63	G1, SAE 16	G1, SAE 16	
80	G1, SAE 16	G1, SAE 16	IN OUT
108	G1, SAE 16	G1, SAE 16	G1 1/4, SAE 20 G1 1/4, SAE 20
130	G1, SAE 16	G1, SAE 16	G1 1/4, SAE 20 G1 1/4, SAE 20

Super Rear			
IN	OUT		
12	G3/4, SAE 12	G3/4, SAE 12	
18	G1, SAE 16	G1/2, SAE 8	
25	G1, SAE 16	G3/4, SAE 12	
32	G1 1/4 SAE 20	G3/4, SAE 12	
40	G1 1/4 SAE 20	G3/4, SAE 12	
50	G1 1/4 SAE 20	G3/4, SAE 12	S02
63	G1 1/4 SAE 20	G3/4, SAE 12	
80	G1 1/2 SAE 24	G1, SAE 16	IN OUT
108	G1 1/2 SAE 24	G1, SAE 16	G1 1/4, SAE 20 G1 1/4, SAE 16
130	G1 1/2 SAE 24	G1, SAE 16	G1 1/4, SAE 20 G1 1/4, SAE 16