

DR – Hydraulic pressure controller, clockwise rotation, mounting flange C,53

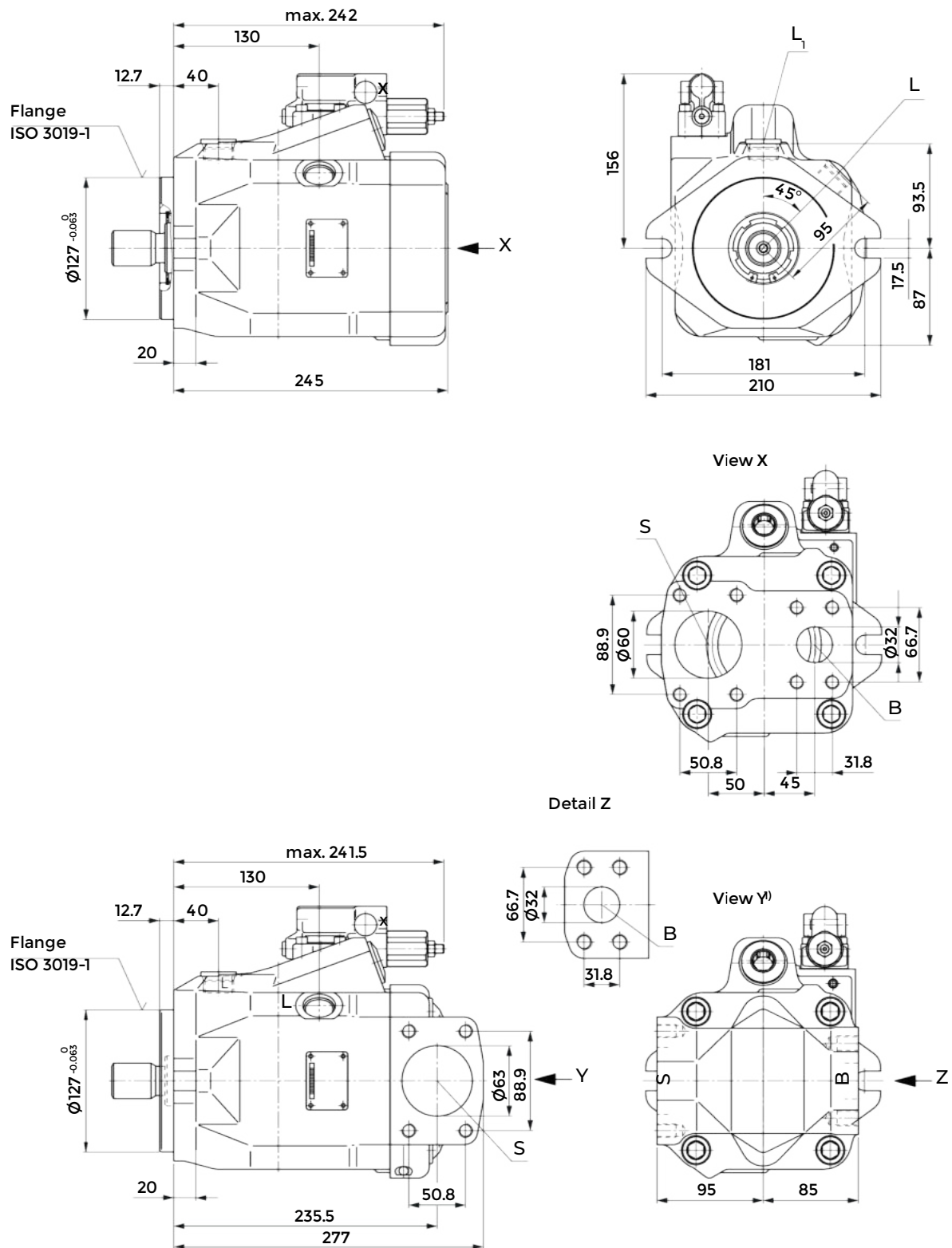

DR – Hydraulic pressure controller, clockwise rotation, mounting flange D,53

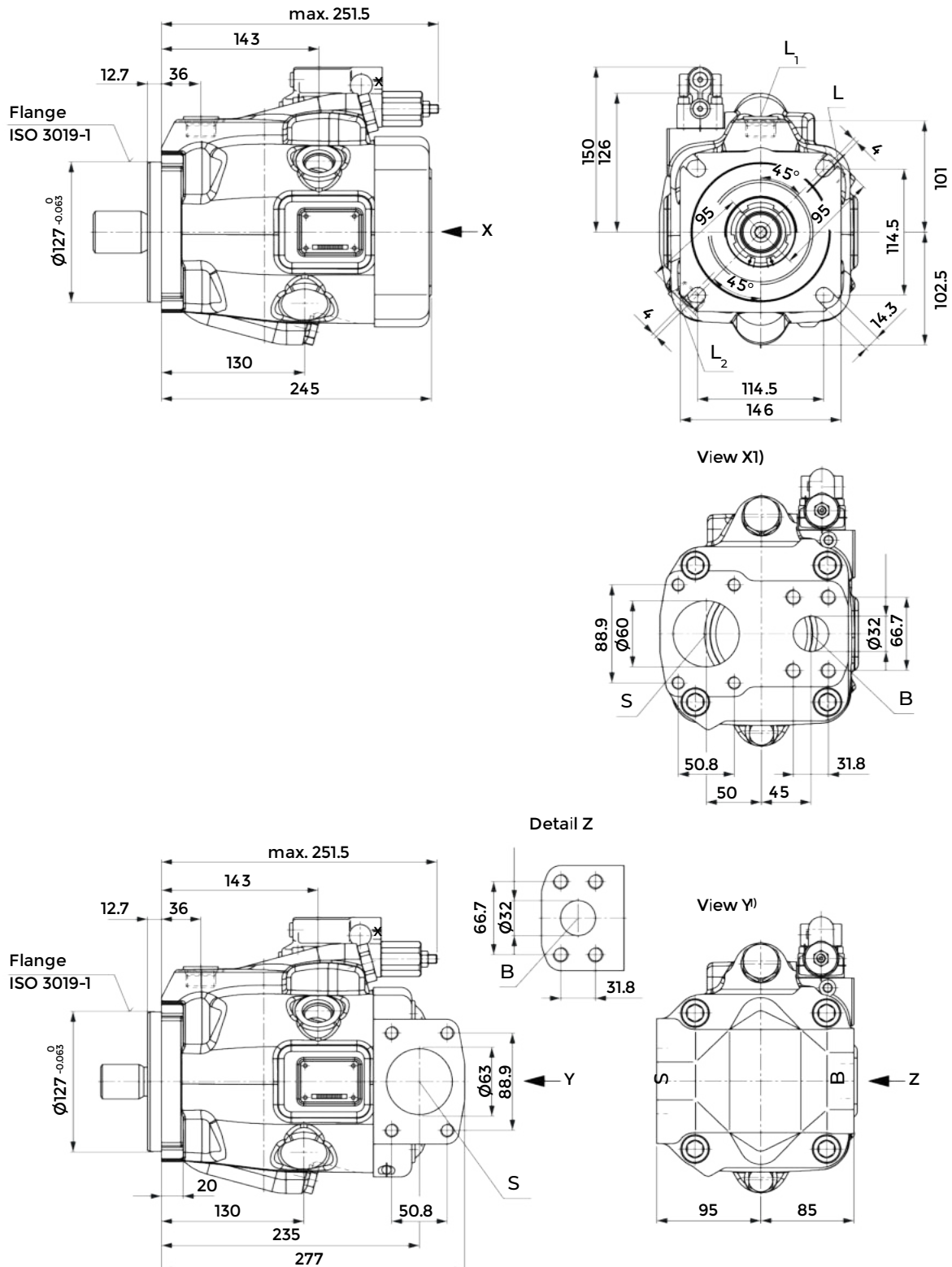

▼ Splined shaft 1 1/2 in SAE J744

S – 17T 12/24 DP1)

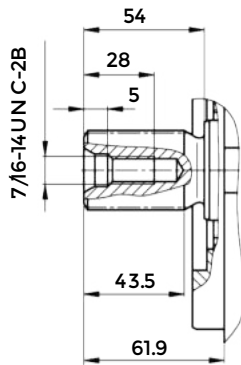

▼ Splined shaft 1 1/2 in SAE J744

R – 17T 12/24 DP1)

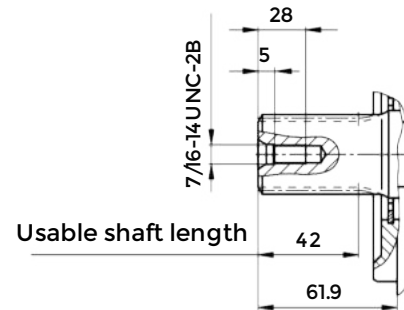

▼ Splined shaft 1 1/4 in SAE J744

U – 14T 12/24 DP1)

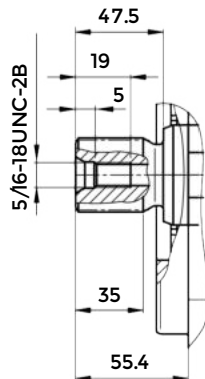

▼ Splined shaft 1 1/4 in SAE J744

W – 14T 12/24 DP1)

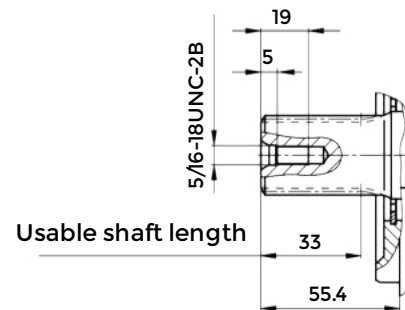

## -Technical Data

Size	NG		10	18	28	45	60	63	72	85	100	
Displacement, geometric, per revolution	$V_g$ max	cm <sup>3</sup>	10.5	18	28	45	60	63	72	85	100	
Speed maximum	at $V_g$ max	$n_{nom}$	rpm	3600	3300	3000	2600	2700	2600	2600	2300	
	at $V_g < V_g$ max	$n_{max perm}$	rpm	4320	3960	3600	3120	3140	3140	3140	2500	
Flow	at $n_{nom}$ and $V_g$ max	$q_v$ max	l/min	37	59	84	117	162	163	187	230	
	at $n_E = 1500$ rpm	$q_v E$ max	l/min	15	27	42	68	90	95	108	150	
Power	at $n_{nom}$ , $V_g$ max $\Delta p = 250$ bar	$P_{max}$	kW	16	25	35	49	65	68	77	96	
	at $n_E = 1500$ rpm	$P_E$ max	kW	7	11	18	28	37	39	45	62	
Torque	at $V_g$ max $\Delta p = 250$ bar	$T_{max}$	Nm	42	71	111	179	238	250	286	398	
	at $V_g$ max $\Delta p = 100$ bar	$T$	Nm	17	29	45	72	95	100	114	159	
Rotary stiffness of drive shaft	S	c	Nm/rad	9200	11000	22300	37500	65500	65500	65500	143000	143000
	R	c	Nm/rad	-	14800	26300	41000	69400	69400	69400	152900	-
	U	c	Nm/rad	6800	8000	16700	30000	49200	49200	49200	102900	102900
	W	c	Nm/rad	-	-	19900	34400	54000	54000	54000	117900	117900
	P	c	Nm/rad	10700	-	-	-	-	-	-	-	-
	Moment of inertia for rotary group	$J_{rw}$	kgm <sup>2</sup>	0.0006	0.0009	0.0017	0.003	0.0056	0.0056	0.0056	0.012	0.012
Maximum angular acceleration	$\alpha$	rad/s <sup>2</sup>	8000	6800	5500	4000	3300	3300	3300	2700	2700	
Case volume	$V$	l	0.2	0.25	0.3	0.5	0.8	0.8	0.8	1	1	
Weight without through drive (approx.)	$m$	kg	8	11.5	15	18	22	22	22	36	36	
Weight with through drive (approx.)			-	13	18	24	28	28	28	45	45	



01	02	03	04	05	06	07	08	09	10	11	12	13
A10V	O		/	53	-		V					

**Axial piston unit**

18 28 45 63 72 85 100

01	Swashplate design, variable, nominal pressure 250 bar, maximum pressure 315 bar			-	•	•	•	•				A10V
----	---	--	--	---	---	---	---	---	--	--	--	------

**Operation mode**

02	Pump, open circuit											O
----	--------------------	--	--	--	--	--	--	--	--	--	--	---

**Size (NG)**

03	Geometric displacement, see table of values on page 10	18	28	45	63	72	85	100
----	--	----	----	----	----	----	----	-----

**Control devices**

04	Pressure controller	hydraulic		•	•	•	•	•	•	•	•	DR	
	with flow controller	hydraulic	X-T open	•	•	•	•	•	•	•	•	DRF	
			X-T plugged with flushing function	•	•	•	•	•	•	•	•	DRS	
			X-T plugged without flushing function	•	•	•	•	•	•	•	•	DRSC	
			remotely operated	•	•	•	•	•	•	•	•	DRG	
	with pressure cut-off	electric	negative control	U = 12 V	-	•	-	•	•	•	•	ED71	
				U = 24 V	-	•	-	•	•	•	•	ED72	
		electric	positive control	U = 12 V	-	•	-	•	•	•	•	ER71	
				U = 24 V	-	•	-	•	•	•	•	ER72	
	Pressure-flow power control		electric control (negative control)	○	○	○	○	○	•	•	•	EF..	
	Power control with pressure cut-off	hydraulic	start of control from	10 to 35 bar	•	•	•	•	•	•	•	•	LA5D
				36 to 70 bar	•	•	•	•	•	•	•	•	LA6D
				71 to 105 bar	•	•	•	•	•	•	•	•	LA7D
				106 to 140 bar	•	•	•	•	•	•	•	•	LA8D
				141 to 230 bar	•	•	•	•	•	•	•	•	•
	remotely operated	hydraulic	start of control	see LA.D	•	•	•	•	•	•	•	LA.DG	
	flow control, X-T plugged	hydraulic	start of control	see LA.D	•	•	•	•	•	•	•	•	LA.DS
		electrically overridable (negative control)	start of control	see LA.D	•	•	•	•	•	•	•	•	LA.S
	Electro-proportional control		positive control										
	with pressure control			U = 12 V	•	•	•	•	•	•	•	•	EP1D
U = 24 V				•	•	•	•	•	•	•	•	•	EP2D
with pressure and flow control (load-sensing)		X-T open	U = 12 V	•	•	•	•	•	•	•	•	EP1DF	
			U = 24 V	•	•	•	•	•	•	•	•	•	EP2DF
with pressure and flow control (load-sensing)		X-T plugged	U = 12 V	•	•	•	•	•	•	•	•	EP1DS	
			U = 24 V	•	•	•	•	•	•	•	•	•	EP2DS
with electro-hydraulic pressure control			U = 12 V	•	•	•	•	•	•	•	•	EP1ED	
			U = 24 V	•	•	•	•	•	•	•	•	•	EP2ED

01	02	03	04	05	06	07	08	09	10	11	12	13
A10V	O		/	53	-		V					

**Control devices**

18 28 45 63 72 85 100

04	Electro-proportional control	positive control										
	with pressure control		U = 12 V	•	•	•	•	•	•	•	•	EK1D
			U = 24 V	•	•	•	•	•	•	•	•	EK2D
	with pressure and flow control (load-sensing)	X-T open	U = 12 V	•	•	•	•	•	•	•	•	EK1DF
			U = 24 V	•	•	•	•	•	•	•	•	EP2DF
	with pressure and flow control (load-sensing)	X-T plugged	U = 12 V	•	•	•	•	•	•	•	•	EP1DS
			U = 24 V	•	•	•	•	•	•	•	•	EP2DS
	electro-hydraulic pressure control with controller cut-off		U = 12 V	•	•	•	•	•	•	•	•	EP1ED
U = 24 V			•	•	•	•	•	•	•	•	EP2ED	

**Series**

05	Series 5, index 3	•	•	•	•	•	•	•	•	•	•	53
----	-------------------	---	---	---	---	---	---	---	---	---	---	----

**Direction of rotation**

06	View on drive shaft	clockwise										R
		counter-clockwise										L

**Sealing material**

07	FKM (fluor-caoutchouc)											V
----	------------------------	--	--	--	--	--	--	--	--	--	--	---

**Drive shaft**

08	Splined shaft ANSI B92.1a	standard shaft	•	•	•	•	•	•	•	•	•	S
		similar to shaft "S" however for higher input torque	•	•	•	•	•	•	•	•	•	R
		reduced diameter, limited suitability for through drive	•	•	•	•	•	•	•	•	•	U
		similar to shaft "U", however for higher torque	-	•	•	•	•	•	•	•	•	W

**Mounting flange**

09	ISO 3019-1 (SAE)	2-hole	•	•	•	•	•	•	•	•	•	C
		4-hole	-	-	-	•	•	•	•	•	•	D

**Working port**

10	SAE flange port fastening thread, metric	rear	not for through drive	•	•	•	•	•	•	•	•	11
		at side, opposite	for through drive	•	•	•	•	•	•	•	•	12
		at side, offset 90°	not for through drive; available only for counter-clockwise direction of rotation	-	-	•	-	-	-	-	-	13

01	02	03	04	05	06	07	08	09	10	11	12	13
<b>A10V</b>	<b>O</b>			<b>/</b>	<b>53</b>		<b>-</b>	<b>V</b>				

**Through drive**

11	Flange ISO 3019-1 Diameter	Hub for splined shaft Diameter								
			18	28	45	63	72	85	100	
	without through drive		•	•	•	•	•	•	•	N00
82-2 (A)	5/8 in	9T 16/32DP	•	•	•	•	•	•	•	K01
		11T 16/32DP	•	•	•	•	•	•	•	K52
101-2 (B)	7/8 in	13T 16/32DP	-	•	•	•	•	•	•	K68
	1 in	15T 16/32DP	-	-	•	•	•	•	•	K04
127-4 (C)	1 1/4 in	14T 12/24DP	-	-	-	•	•	•	•	K15
	1 1/2 in	17T 12/24DP	-	-	-	-	-	•	•	K16
127-2 (C)	1 1/4 in	14T12/24DP	-	-	-	-	-	•	•	K07
	1 1/2 in	17T 12/24DP	-	-	-	-	-	•	•	K24

**Connectors for solenoids**

12	Without connector (without solenoid, with hydraulic control only, without code)								
		18	28	45	63	72	85	100	
	Without connector (without solenoid, with hydraulic control only, without code)	•	•	•	•	•	•	•	
	DEUTSCH - molded connector, 2-pin - without suppressor diode (for electric controls)	•	•	•	•	•	•	•	P

• = Available    ◦ = On request    - = Not available