

Dimensions Size;

HA10VO31-18cc

DFR / DFR1 / DRSC – Pressure and flow control, hydraulic; clockwise rotation, version: SAE ports

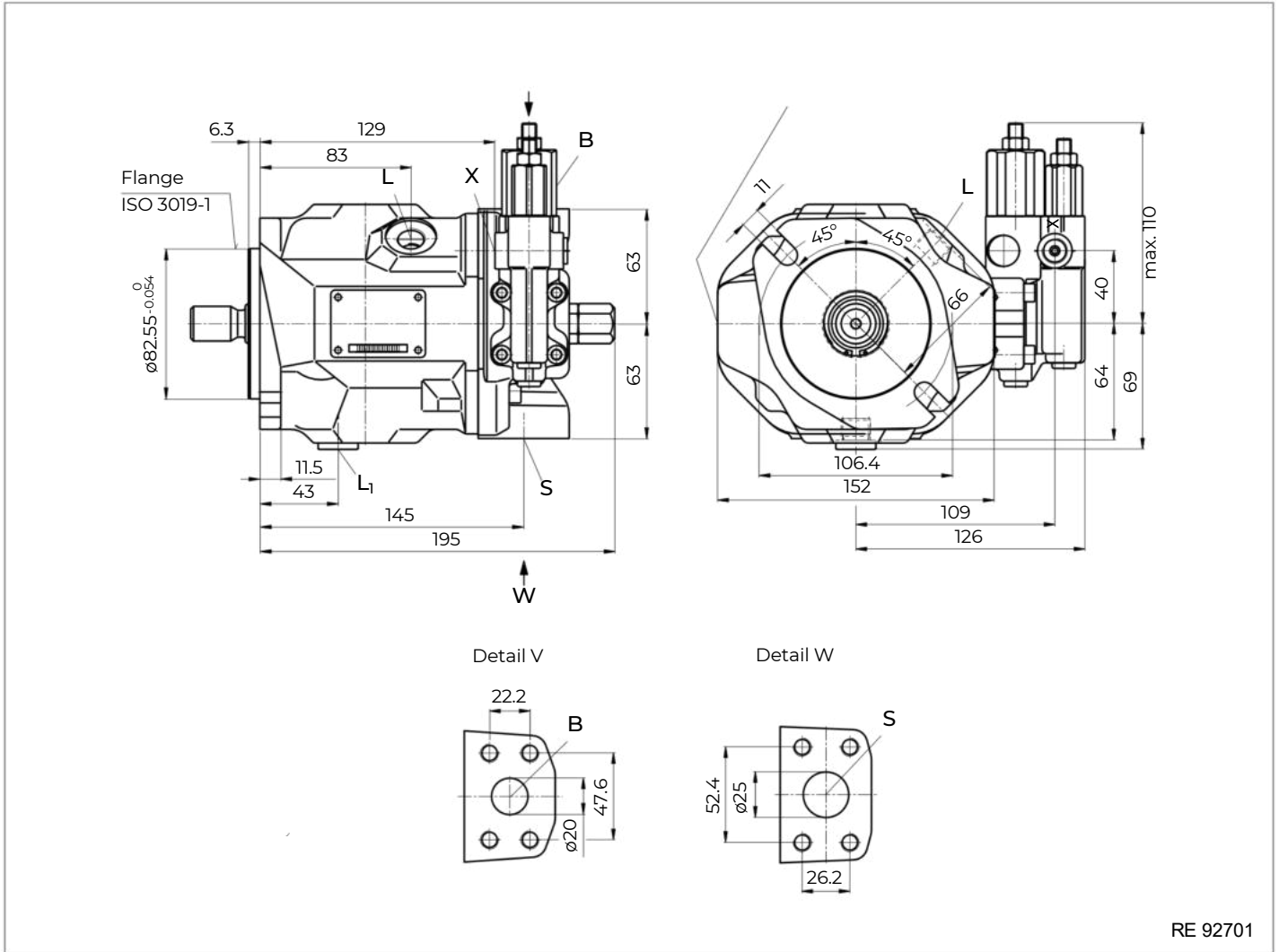

RE 92701



-Technical Data

Size	NG		18	28	45	71	88	100	140	
Displacement, geometric, per revolution	$V_g \text{ max}$	cm ³	18	28	45	71	88	100	140	
Rotational speed maximum)	at $V_g \text{ max}$	n_{nom}	rpm	3300	3000	2600	2200	2100	2000	1800
	at $V_g < V_g \text{ max}^2$)	$n_{\text{max perm}}$	rpm	3900	3600	3100	2600	2500	2400	2100
Flow	at n_{nom} and $V_g \text{ max}$	$q_v \text{ max}$	l/min	59	84	117	156	185	200	252
	at $n_E = 1500$ rpm and $V_g \text{ max}$	$q_{vE} \text{ max}$	l/min	27	42	68	107	132	150	210
Power at $\Delta p = 280$ bar	at n_{nom} , $V_g \text{ max}$	P_{max}	kW	28	39	55	73	86	93	118
	at $n_E = 1500$ rpm and $V_g \text{ max}$	$P_{E \text{ max}}$	kW	12.6	20	32	50	62	70	98
Torque at $V_g \text{ max}$ and	$\Delta p = 280$ bar	T_{max}	Nm	80	125	200	316	392	445	623
	$\Delta p = 100$ bar	T	Nm	30	45	72	113	140	159	223
Rotary stiffness of drive shaft	S	c	Nm/rad	11087	22317	37500	71884	71884	121142	169437
	R	c	Nm/rad	14850	26360	41025	76545	76545	-	-
	U	c	Nm/rad	8090	16695	30077	52779	52779	91093	-
	W	c	Nm/rad	-	19898	34463	57460	57460	101847	165594
Moment of inertia for rotary group	J_{rw}	kgm ²	0.00093	0.0017	0.0033	0.0083	0.0083	0.0167	0.0242	
Maximum angular acceleration)	α	rad/s ²	6800	5500	4000	2900	2600	2400	2000	
Case volume	V	l	0.4	0.7	1.0	1.6	1.6	2.2	3.0	
Weight without through drive (approx.)	m	kg	12.9	18	23.5	35.2	35.2	49.5	65.4	
Weight with through drive (approx.)			13.8	19.3	25.1	38	38	55.4	74.4	

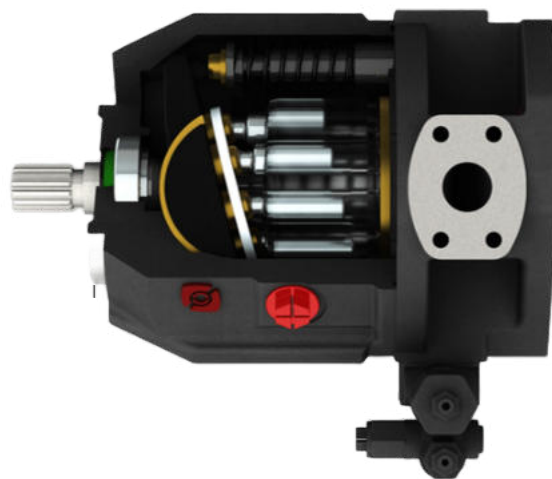

01	02	03	04	05	06	07	08	09	10	11	12	13
	A10V(S)	O			/	31		-	V			

Version									18	28	45	71	88	100	140
01	Standard version (without code)							•	•	•	•	•	•	•	
	High-speed version (external dimensions are the same as the standard version)							-	-	•	•	-	•	•	H

Axial piston unit

02	Swashplate design, variable, nominal pressure 280 bar, maximum pressure 350 bar							•	-	-	-	-	-	-	A10VS
								-	•	•	•	•	•	•	A10V

Operating mode

03	Pump, open circuit											O
----	--------------------	--	--	--	--	--	--	--	--	--	--	---

Size (NG)

04	Geometric displacement, see table of values on pages 6 and 7							18	28	45	71	88	100	140
----	--	--	--	--	--	--	--	----	----	----	----	----	-----	-----

Control device

05	Two-point control, direct operated							•	•	•	•	•	•	•	DG
	Pressure controller	hydraulic					•	•	•	•	•	•	•	•	DR
	with flow controller	hydraulic	X-T open				•	•	•	•	•	•	•	•	DFR
			X-T plugged with flushing function				•	•	•	•	•	•	•	•	DFR1
			X-T plugged without flushing function				•	•	•	•	•	•	•	•	DRSC
	with flow and differential pressure control, electrically variable							•	•	•	•	•	•	•	EF ¹⁾
	with pressure cut-off	hydraulic	remote controlled				•	•	•	•	•	•	•	•	DRG
			electrical	negative control	U = 12 V		•	•	•	•	•	•	•	•	•
		U = 24 V			•	•	•	•	•	•	•	•	•	•	ED72
		electrical	positive control	U = 12 V		•	•	•	•	•	•	•	•	•	ER71
				U = 24 V		•	•	•	•	•	•	•	•	•	•
	Pressure-flow power control							-	•	•	•	•	•	•	DFLR

Series

06	Series 3, index 1											31
----	-------------------	--	--	--	--	--	--	--	--	--	--	----

Direction of rotation

07	Viewed on drive shaft		clockwise									R
			counter-clockwise									L

Sealing material

08	FKM (fluoroelastomer)											V
----	-----------------------	--	--	--	--	--	--	--	--	--	--	---

Drive shaft

09	Splined shaft ANSI B92.1a	standard shaft					•	•	•	•	•	•	•	•	S
		similar to shaft "S" however for higher input torque					•	•	•	•	•	-	-	•	R
		reduced diameter, limited suitability for through drive (see table of values, page 9)					•	•	•	•	•	•	○	•	U
		same as "U", higher torque; limited suitability for through drive (see table of values, page 9)					-	•	•	•	•	•	•	•	W

Mounting flange

10	ISO 3019-1 (SAE)		2-hole									S
			4-hole									R

01	02	03	04	05	06	07	08	09	10	11	12	13
	A10V(S)	O			/	31		-	V			

Working port

				18	28	45	71	88	100	140	
11	SAE flange ports according to J518 Working ports metric	Fastening thread metric; rear	not for through drive	-	•	•	-	-	•	•	11
				-	-	-	•	•	-	-	41
		Fastening thread metric; lateral top bottom	for through drive	•	•	•	-	-	•	•	12
				-	-	-	•	•	-	-	42
	SAE flange ports according to J518 Working ports UNF	Fastening thread UNF; rear	not for through drive	-	•	•	-	-	•	•	61
				-	-	-	•	•	-	-	91
	Fastening thread UNF; lateral top bottom	for through drive	•	•	•	-	-	•	•	62	
		-	-	-	•	•	-	-	92		

Through drive

			18	28	45	71	88	100	140		
12	Flange ISO 3019-1 Diameter	Hub for splined shaft Diameter									
	without through drive		•	•	•	•	•	•	•	•	N00
	82-2 (A)	5/8 in	9T 16/32DP	•	•	•	•	•	•	•	K01
		3/4 in	11T 16/32DP	•	•	•	•	•	•	•	K52
	101-2 (B)	7/8 in	13T 16/32DP	-	•	•	•	•	•	•	K68
		1 in	15T 16/32DP	-	-	•	•	•	•	•	K04
	127-2 (C)	1 1/4 in	14T 12/24DP	-	-	-	•	•	•	•	K07
		1 1/2 in	17T 12/24DP	-	-	-	-	-	•	•	K24
	152-4 (D)	1 3/4 in	13T 8/16DP	-	-	-	-	-	-	•	K17

• = Available ◦ = On request - = Not available