

# 2PE 40 - SAE C - 4 BOLT

SAE B 7/8" 13T-16/32DP

## SAE C - 4 BOLT MOUNTING (SAE J744)

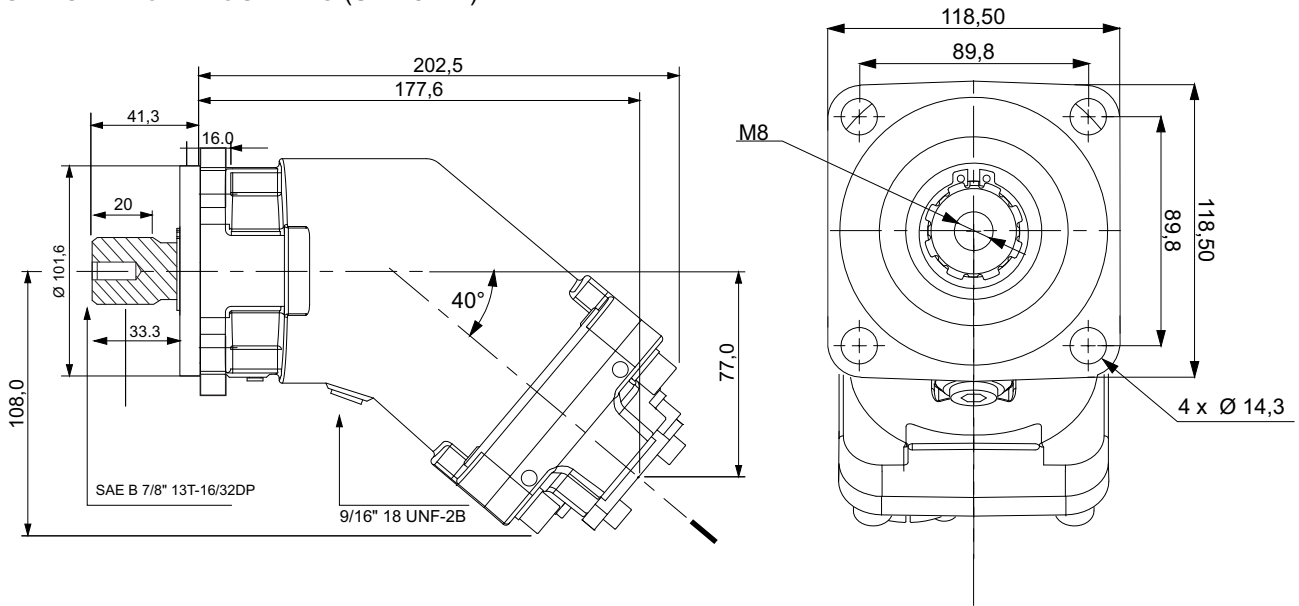

### Spline Shaft

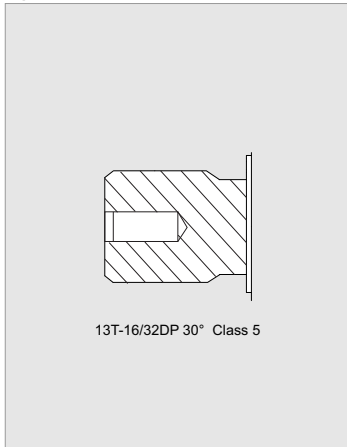

### Keyed Shaft

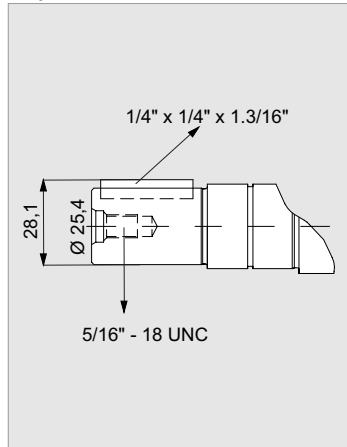

### Back Cover

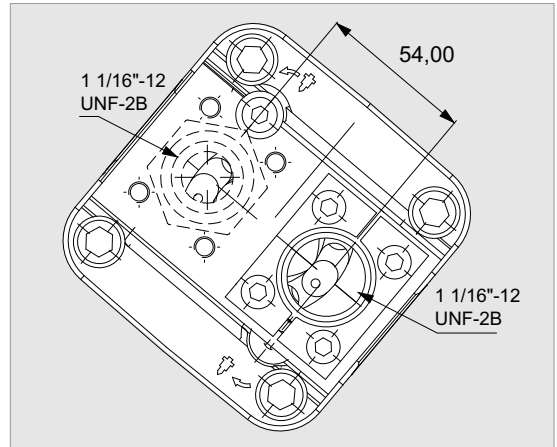

Flow, Speed, Pressure List of 2PE 40

<b>x 1000 rpm</b>	40,20 cc
<b>x 1500 rpm</b>	60,30 cc
<b>Max. Continuous Pump Speed</b>	1900 rpm
<b>Max. Limited Pump Speed</b>	2500 rpm
<b>Max. Continuous Pressure</b>	350 bar
<b>Max. Intermit. Peak Pressure</b>	400 bar
<b>Max. Torque at 350 bar</b>	240 Nm
<b>Weight without inlet fitting</b>	11,50 kg
<b>Weight with inlet fitting</b>	11,90 kg
<b>Rotation</b>	CW-CCW

