

MOUNTING FLANGE (SAE J744)

-SB4

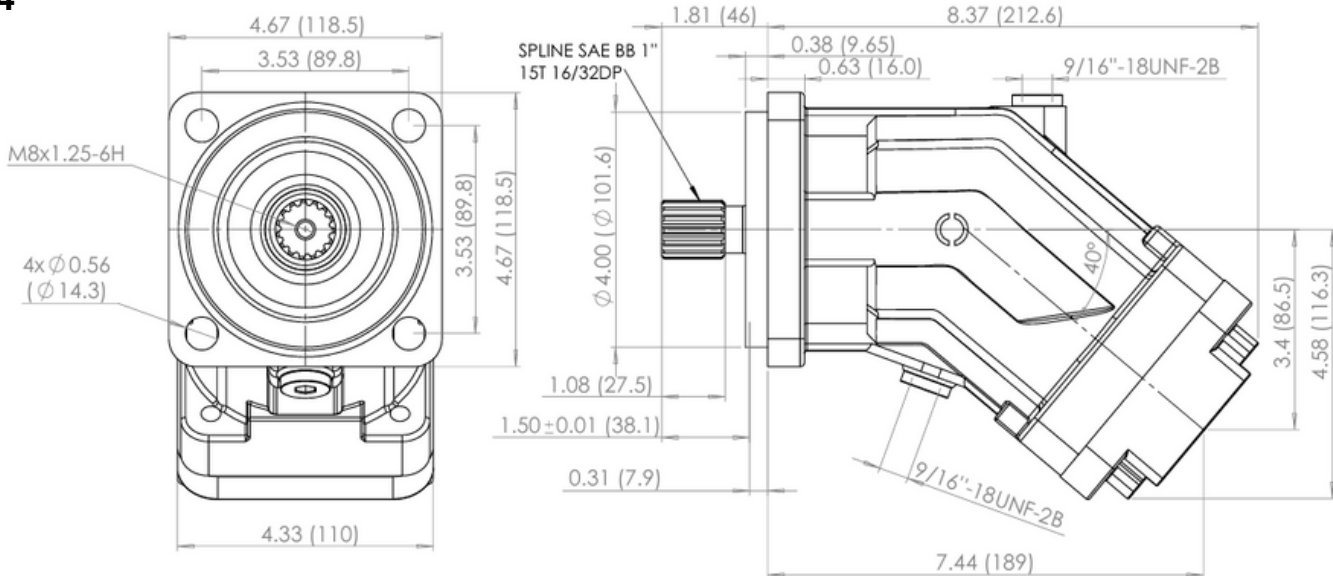

-SC4

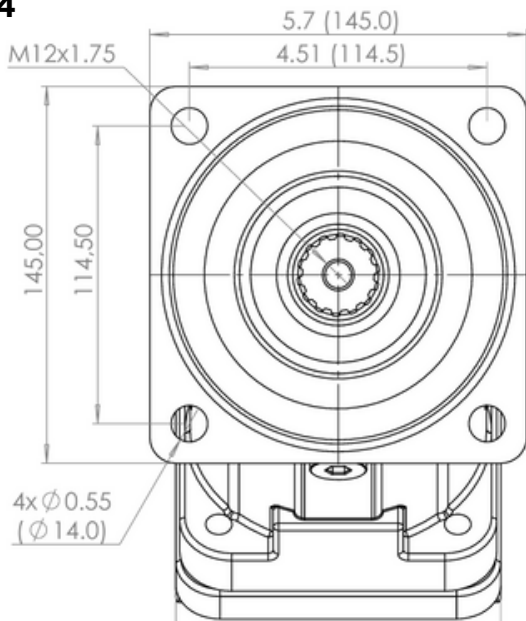

-PORTING OPTIONS

With BSP, SAE O-ring boss, ISO 6149 Threading



-Shaft

Spline Shaft



Spline Shaft

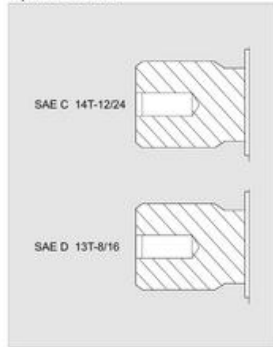

Keyed Shaft

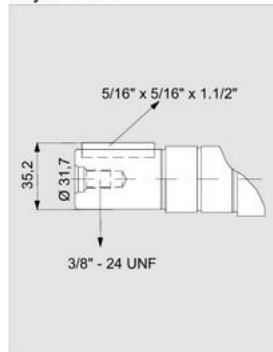

Keyed Shaft

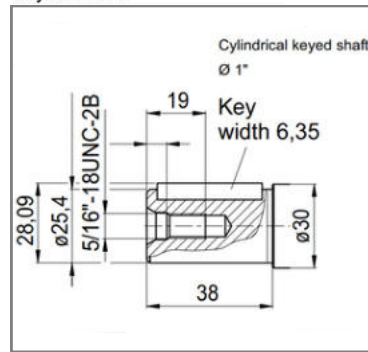

Compare Table of Torque

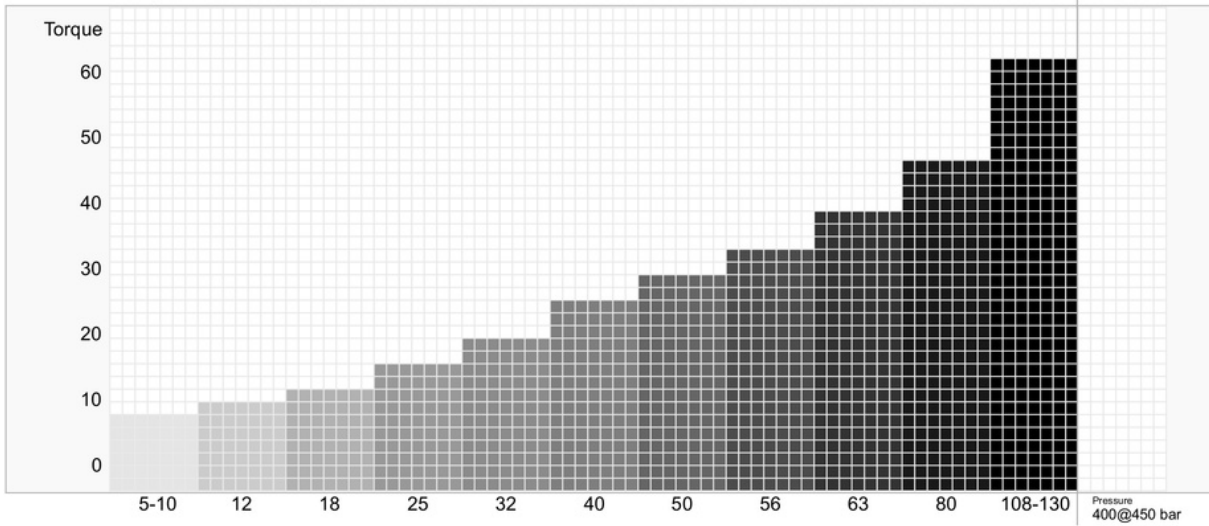

Efficiency of 2PEM Motors

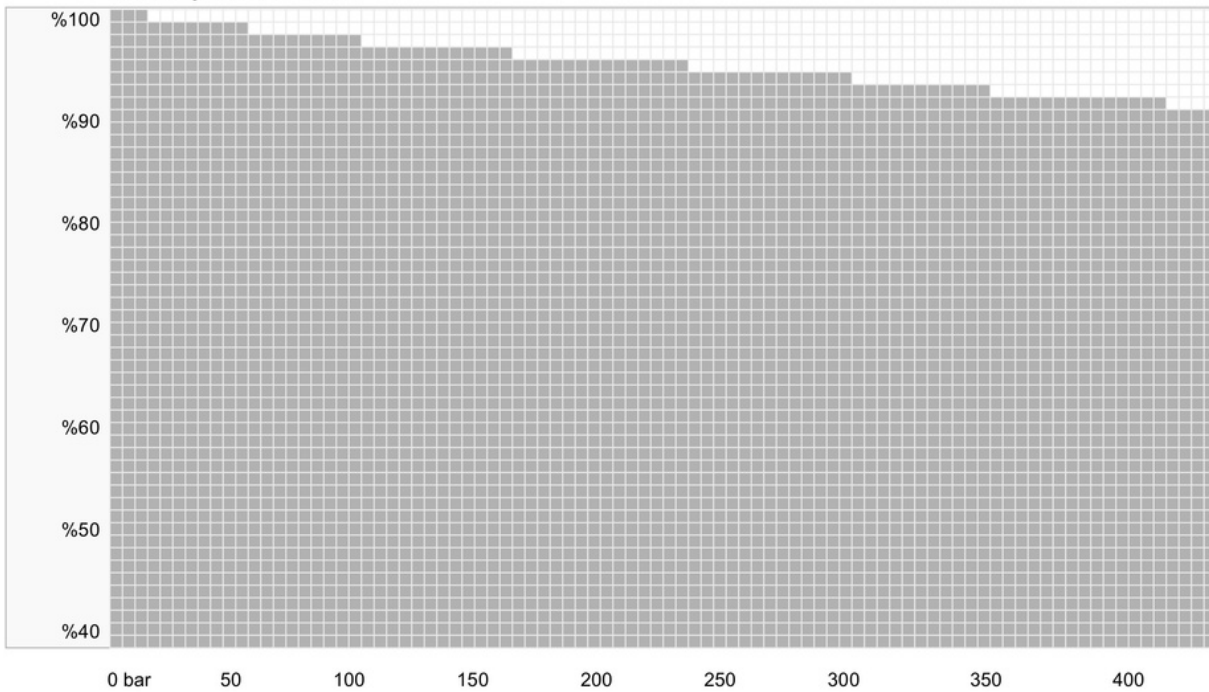

C-2PEM: Ordering Code and Specifications Table

| Type Code | Displacement (cm3) | Rotation | Version | Sealing | Mounting Flange | Shaft | Flow |
|-----------|-----------------------------------|---------------|-----------------------|----------------------|------------------------------|------------------------------|---------------------------------|
| C-2PEM | 12,18,25,32, 40,50,63,80, 108,130 | Both (cw,ccw) | Special Classic (S,C) | Nitrile, Viton (N,V) | According the Specifications | According the Specifications | R, S, RS (Super, Bidirectional) |

| | 12 | 18 | 25 | 32 | 40 | 50 | 63 | 80 | 108 | 130 | |
|------------|----|----|----|----|----|----|----|----|-----|-----|--------------|
| SB2 | ● | ● | ● | ● | ● | | | | | | SAE B-2 Hole |
| SB4 | ● | ● | ● | ● | ● | ● | ● | | | | SAE B-4 Hole |
| SC4 | | | | | | ● | ● | ● | ● | ● | SAE C-4 Hole |

| | 12 | 18 | 25 | 32 | 40 | 50 | 63 | 80 | 108 | 130 | |
|--------------|----|----|----|----|----|----|----|----|-----|-----|-----------------------|
| B13 | ● | ● | ● | ● | ● | ● | ● | | | | SAE B 13T 16/32 |
| BB15 | | | | ● | ● | ● | ● | | | | SAE BB 15T 16/32 |
| C14 | | | | | | ● | ● | ● | ● | ● | SAE C 14T 12/24 |
| D13 | | | | | | | | ● | ● | ● | SAE D 13T 8/16 |
| K1 | ● | ● | ● | ● | ● | ● | ● | | | | 1" Parallel Keyed |
| K1114 | | | | ● | ● | ● | ● | ● | ● | ● | 1 1/4" Parallel Keyed |

ISO1179, SAE J1926

*Avaliable on Request

| | Rear Ports |
|------------|--------------|
| 12 | G3/4, SAE 12 |
| 18 | G3/4, SAE 12 |
| 25 | G3/4, SAE 12 |
| 32 | G1, SAE 16 |
| 40 | G1, SAE 16 |
| 50 | G1, SAE 16 |
| 63 | G1, SAE 16 |
| 80 | G1, SAE 16 |
| 108 | G1, SAE 16 |
| 130 | G1, SAE 16 |

| | R02 |
|------------|------------|
| 80 | G1, SAE 16 |
| 108 | G1, SAE 16 |
| 130 | G1, SAE 16 |

| | Side Ports |
|------------|--------------|
| 12 | G3/4, SAE 12 |
| 18 | G3/4, SAE 12 |
| 25 | G3/4, SAE 12 |
| 32 | G1, SAE 16 |
| 40 | G1, SAE 16 |
| 50 | G1, SAE 16 |
| 63 | G1, SAE 16 |
| 80 | G1, SAE 16 |
| 108 | G1, SAE 16 |
| 130 | G1, SAE 16 |

| | Rear + Side Ports | |
|------------|-------------------|--------------|
| | Rear | Side |
| 12 | G3/4, SAE 12 | G3/4, SAE 12 |
| 18 | G3/4, SAE 12 | G1/2, SAE 8 |
| 25 | G3/4, SAE 12 | G3/4, SAE 12 |
| 32 | G1, SAE 16 | G1, SAE 16 |
| 40 | G1, SAE 16 | G1, SAE 16 |
| 50 | G1, SAE 16 | G1, SAE 16 |
| 63 | G1, SAE 16 | G1, SAE 16 |
| 80 | G1, SAE 16 | G1, SAE 16 |
| 108 | G1, SAE 16 | G1, SAE 16 |
| 130 | G1, SAE 16 | G1, SAE 16 |

