

PR – Hydraulic pressure controller, clockwise rotation, 53

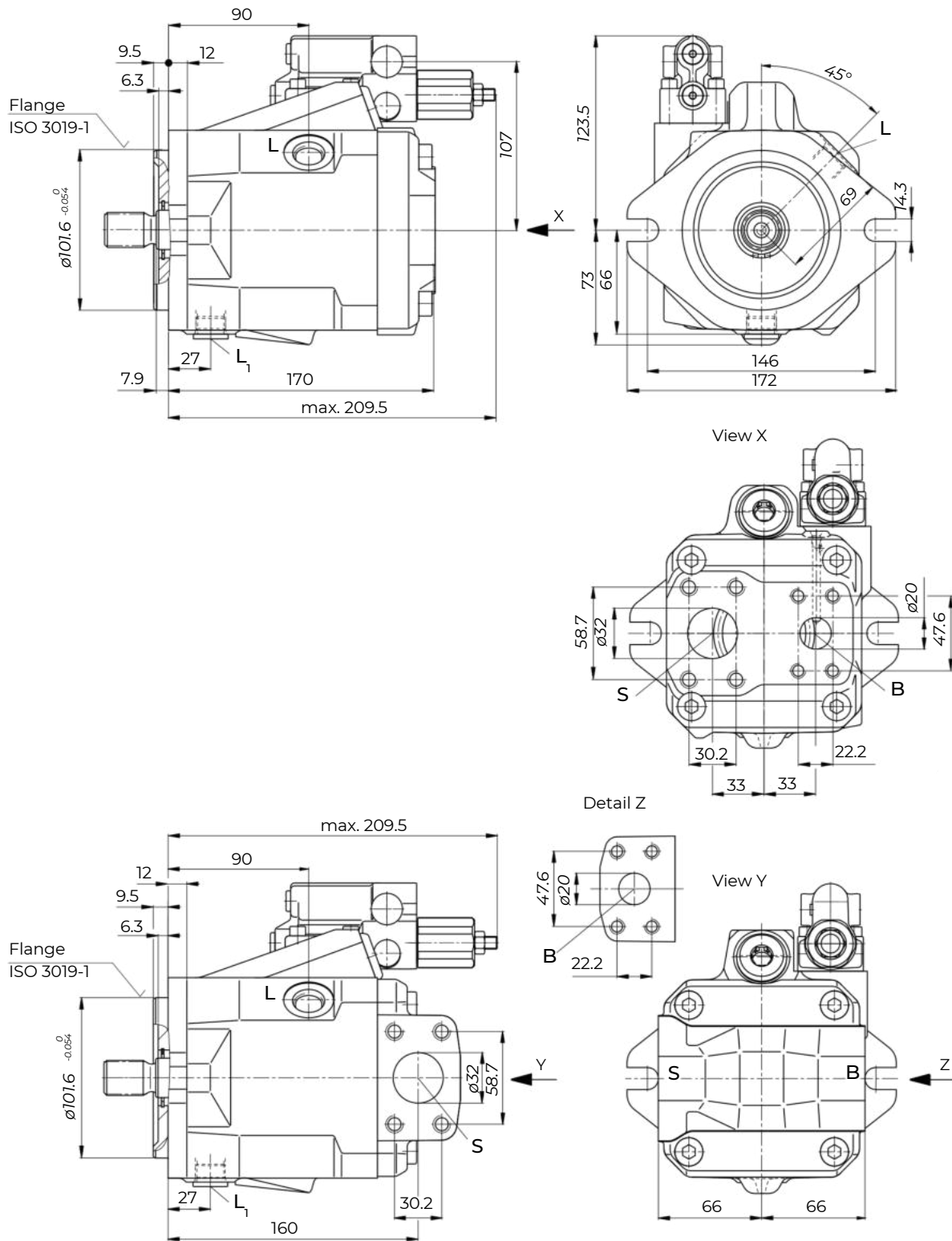

▼ Splined shaft 7/8 in (SAE J744)

S – 13T 16/32DP1)

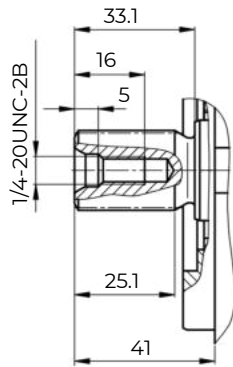

▼ Splined shaft 7/8 in (SAE J744)

R – 13T 16/32DP1)2)

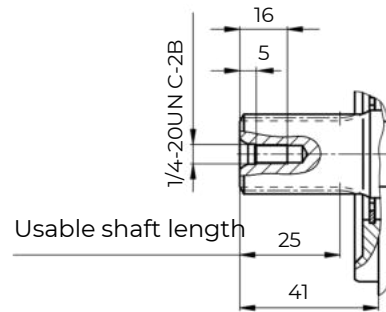

▼ Splined shaft 3/4 in (SAE J744)

U – 11T 16/32DP1)

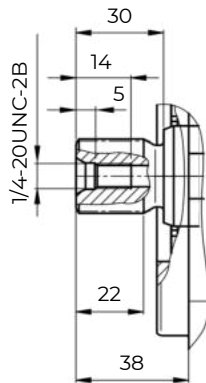

▼ Splined shaft 3/4 in (SAE J744)

W – 11T 16/32DP1)2)

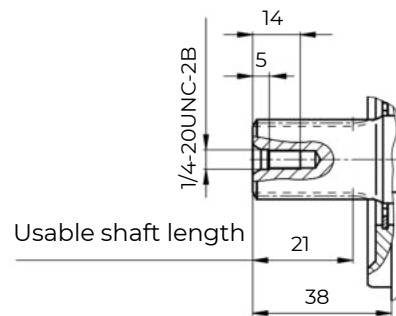

-Technical Data

Size	NG		10	18	28	45	60	63	72	85	100
Displacement, geometric, per revolution	$V_{g \max}$	cm ³	10.5	18	28	45	60	63	72	85	100
Speed maximum	at $V_{g \max}$	n_{nom}	rpm	3600	3300	3000	2600	2700	2600	2600	2300
	at $V_g < V_{g \max}$	$n_{max \text{ perm}}$	rpm	4320	3960	3600	3120	3140	3140	3000	2500
Flow	at n_{nom} and $V_{g \max}$	$q_{v \max}$	l/min	37	59	84	117	162	163	187	230
	at $n_E = 1500$ rpm	$q_{vE \max}$	l/min	15	27	42	68	90	95	108	150
Power	at n_{nom} , $V_{g \max}$ $\Delta p = 250$ bar	P_{max}	kW	16	25	35	49	65	68	77	96
	at $n_E = 1500$ rpm	$P_{E \max}$	kW	7	11	18	28	37	39	45	62
Torque	at $V_{g \max}$ $\Delta p = 250$ bar	T_{max}	Nm	42	71	111	179	238	250	286	338
	at $V_{g \max}$ $\Delta p = 100$ bar	T	Nm	17	29	45	72	95	100	114	159
Rotary stiffness of drive shaft	S	c	Nm/rad	9200	11000	22300	37500	65500	65500	65500	143000
	R	c	Nm/rad	-	14800	26300	41000	69400	69400	69400	152900
	U	c	Nm/rad	6800	8000	16700	30000	49200	49200	49200	102900
	W	c	Nm/rad	-	-	19900	34400	54000	54000	54000	117900
	P	c	Nm/rad	10700	-	-	-	-	-	-	-
Moment of inertia for rotary group	J_{rw}	kgm ²	0.0006	0.0009	0.0017	0.003	0.0056	0.0056	0.0056	0.012	0.012
Maximum angular acceleration	α	rad/s ²	8000	6800	5500	4000	3300	3300	3300	2700	2700
Case volume	V	l	0.2	0.25	0.3	0.5	0.8	0.8	0.8	1	1
Weight without through drive (approx.)	m	kg	8	11.5	15	18	22	22	22	36	36
Weight with through drive (approx.)			-	13	18	24	28	28	28	45	45



HA10VO53: Ordering Code and Specifications Table

Type Code	Displacement (cm ³)	Rotation	Version	Sealing	Control	Ports	Mounting Flange	Shaft	Through Drive
HA10VO53	28,45,63,60	Right, Left (cw,ccw)	Special Classic (S,C)	Nitrile, Viton (N,V)	LS-X PR-R LS-C PT-L PR	Side Metric Side Unf Rear Metric Rear Unf (SM,SUN, RM, RUN)	2H (ISO-3019-1) (SAE2 Hole)	Standart (S) High Torque (T)	T01 T58 T68 T04 T07

LS-X	Load Sensing X Decompression
LS-C	Load Sensing Closed
PR-R	Pressure Remote
PT-L	Pressure Torque Limiter
PR	Hydraulic Pressure Control

28 cc	●	●			
45 cc		●	●		
60 cc			●	●	●
63 cc			●	●	●
	11T	13T	15T	14T	K32-1

	Through Drive			Flange	Shaft
T01	●	●	●	SAEA2	5/8" 9T 16/32 DP
T52	●	●	●	SAEA2	3/4" 11T 16/32 DP
T68	●	●	●	SAEB2	7/8" 13T 16/32 DP
T04	●	●	●	SAEB2	1" 15T 16/32 DP
T07			●	SAEC2	1 1/4" 14T 12/24 DP
	28	45	63		

