

PH 12

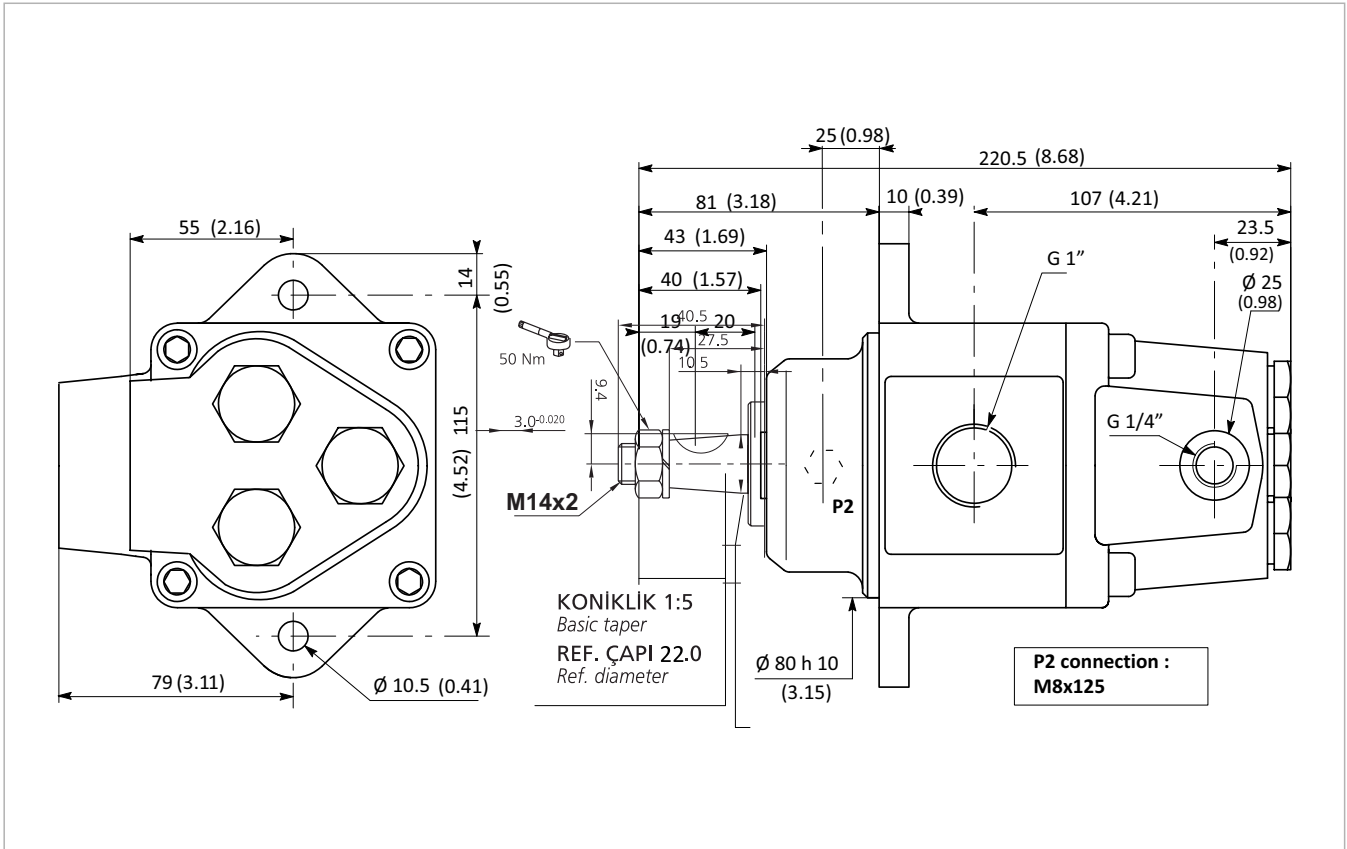

x 1000 rpm	7,80 cc
x 1500 rpm	11,70 cc
Max. Continuous Pump Speed	2800 rpm
Max. Limited Pump Speed	3000 rpm
Max. Continuous Pressure	450 bar
Max. Intermit. Peak Pressure	500 bar
Weight without inlet fitting	8,00 kg
Weight with inlet fitting	8,15 kg
Fluid	Min.B.Hyd.Oil
Inlet	G 1"
Outlet	G 1/4"



CW

Rotation :
Fixed-Clock Wise